

PD-2100 Series 2200 Series

USER'S MANUAL

**VFD CUSTOMER DISPLAY for
ALPHANUMERICAL DISPLAY
in 2 x 20 format**

Rev. : A

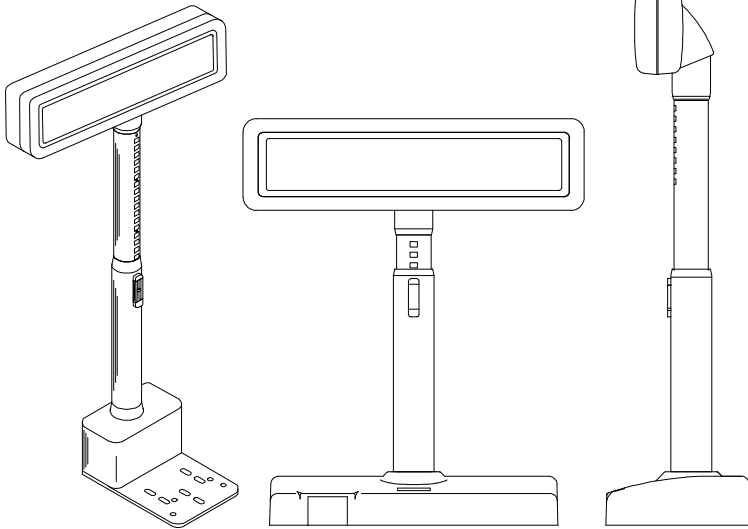



SOME IMPORTANT NOTES

FCC NOTICE

This equipment generates, uses, and can radiate radio frequency energy and, if not installed and used in accordance with the instructions manual, may cause interference to radio communications. It has been tested and found to comply with limits for a Class A digital device pursuant to subpart J of Part 15 of FCC Rules, which are designed to provide reasonable protection against interference when operated in a commercial environment. Operation of this equipment in a residential area is likely to cause interference in which case the user at his own expense will be required to take whatever measures to correct the interference.

WARRANTY LIMITS

Warranty will terminate automatically when the machine is opened by any person other than the authorized technicians. The user should consult his/her dealer for the problem happened. Warranty voids if the user does not follow the instructions in application of this merchandise. The manufacturer is by no means responsible for any damage or hazard caused by improper application.

ABOUT THIS MANUAL

This manual assists the user to utilize the VFD customer display PD-2100 and PD-2200 series. Both series provide versatile font formats and support various instruction sets. These series of products receive instructions in serial communication protocols and is capable of entering pass through mode for PD-2100SP and PD-2200 so that all instructions received pass on to next connected serial device if properly configured.

The manufacturer of the PD-2100 and PD-2200 series heartily apologizes to the user for reserving the right to change or to modify this manual without notice due to the rapid and constant progress and improvement on science and technology. The user may always obtain the most up to date information through any of our web sites: <http://www.posiflex.com.tw>, <http://www.posiflexuk.com>, <http://www.posiflexusa.com>.

© Copyright Mustek Corp. 2000

TRADE MARKS AND SERVICE MARKS

POSIFLEX is a registered trademark of Mustek Corp.. Other brand and product names are trademarks and registered trademarks and service marks of their respective owners.

CE

TABLE OF CONTENTS

FEATURES	1- 1
MODEL NUMBERS	2- 1
CARTON CONTENTS	3- 1
INSTALLATION	4- 1
PD2100S/S-E Installation (Standard Serial Interface)	4- 1
PD2100SP/SP-E Installation (Serial Pass Through)	4- 2
PD2100PP Installation (Parallel Pass Through)	4- 3
PD2101/PD2201 Installation For PST Series	4- 4
PD2200/PD2200A Installation	4- 4
Establish Power Supply Connector From PC	4- 4
Connect The Display For Both Signals And Power	4- 5
Connect For Pass Through Operation	4- 6
Connect The Optional Power Adaptor	4- 6
MECHANICAL ADJUSTMENT	5- 1
Dimension Drawings	5- 1
Display Frame Common Features	5- 2
Cushion Against Shock Coming From Any Direction For PD2100S/S-E/SP/SP-E/PP	5- 2
Stand - Plate Accessory For PD2100S/S-E/SP/SP-E/PP	5- 2
FUNCTIONAL TEST	6- 1
For PD2100S/S-E/SP/SP-E and PD2200/PD2200A	6- 1
For PD2100PP	6- 1
INTERFACE	7- 1
PD2100S/S-E/SP/SP-E	7- 1
PD2100PP	7- 2
PD2200/PD2200A	7- 2
COMMAND EMULATION	8- 1
General Concept	8- 1
Futaba Emulation Mode	8- 2
Noritake Emulation Mode (Default Setting)	8- 2



Aedex Emulation Mode	8 - 3
ADM Emulation Mode	8 - 4
Epson Emulation Mode	8 - 4
SPECIFICATIONS	9 - 1
Optical	9 - 1
Mechanical	9 - 1
Electrical	9 - 1
Environmental	9 - 1

I. FEATURES

- Bright green vacuum fluorescent display
- Two-line display with 20 characters per line
- Large characters for easy viewing (11.25mm by 7.2mm)
- Long life and trouble free operation
- Secure construction with bumper best for screw on operation in PD2100 series. Generous base best for freely stand alone application in PD2200 series.
- Two adjustable viewing angles
- Pole height adjustable except PD2100PP
- Display frame is horizontally slidable, and 360° rotatable freely
- Brightness adjustable by software
- Simple installation
- Direct interface connection with computers and peripherals
- Standard Serial Interface
- Serial Pass-through Interface with selectable flow control signal by jumper setting for PD2200.
- Support Euro Code Page for PD2100S-E, PD2100SP-E, PD2101-E, PD2200A and PD2201

II. MODEL NUMBERS

Model number	Base (mm)	Interface	Connector	Power source	Code Page
PD2100S	Cushioned small housing 80 x 60 x 51	RS232	5 pin DIN	Posiflex PD power adaptor	U + J
PD2100S-E		RS232			U + E
PD2100SP		RS232	5 pin DIN + 9 pin D		U + J
PD2100SP-E		RS232			U + E
PD2100PP		Centronics	25 pin D		U + J
PD2101	N. A.	RS232	10 pin RJ-45 connector	+5V DC from PST system connector	U + J
PD2101-E		RS232			U + E
PD2200	Large housing 220 x 110 x 41	RS232	9, 25 pin D	+5V DC from PC or Posiflex PD Power adaptor	U + J
PD2200A		RS232			U + J + E
PD2201	N. A.	RS232	10 pin RJ-45 connector	+5V DC from PST system connector	U + J + E

Note:

U: US Code Page

J: JPN Code Page

E: EU Code Page

III. CARTON CONTENTS

1. Pole display, pre-assembled.
2. User's Manual.
3. Cables:
 - a) For PD2100S/S-E/SP/SP-E:
 - CCBLA - 125A (DB-9F to DIN-5M RS232 cable)
 - b) For PD2100PP:
 - CCBLA - 089 - 1 (DB-25M to DB-25F)
 - c) For PD2200/PD2200A:
 - Power supply (inside PC) cable: CCBLA - 141
 - Signal and power cable: CCBLA - 220
4. For PD2100S/S-E/SP/SP-E/PP:
Metal stand plate with mounting screws.
5. AC power adapter:

Model number	AC Power Adaptor Part Number
PD2100S/S-E/ SP/SP-E/PP	CADPTR7.5V1.5A120 or CADPTR7.5V1.5A230
PD2200	CADPTR7.5V1.5A120 or CADPTR7.5V1.5A230 (option)
PD2200A	CADPTR12V1.5A120 or CADPTR12V1.5A230 (option)

Model number	Cable	Metal stand plate with mounting screws	AC Power Adaptor
PD2100S	CCBLA - 125A (DB-9F to DIN-5M RS232 cable)	Yes	Yes
PD2100S-E			
PD2100SP			
PD2100SP-E			
PD2100PP	CCBLA - 089 - 1 (DB-25M to DB-25F)		
PD2200	Power supply (inside PC) cable: CCBLA - 141 and Signal and power cable: CCBLA - 220	N. A.	Option
PD2200A			

Model number	PD2100S/S-E/SP/SP-E	PD2100PP	PD2200/PD2200A
Cable	CCBLA - 125A (DB-9F to DIN-5M RS232 cable)	CCBLA - 089 - 1 (DB-25M to DB-25F)	Power supply (inside PC) cable: CCBLA - 141 and Signal and power cable: CCBLA - 220

IV. INSTALLATION

A. PD2100S/S-E Installation (Standard Serial Interface)

1. Take off the metal plate on the Pole display base cabinet by loosening the screws.

2. Connect the DIN 5 pin plug of the cable CCBLA - 125A to the female DIN 5 pin jack inside the base cabinet and connect the DB9 connector of the cable CCBLA - 125A to the computer's serial port of COM1 or COM2.

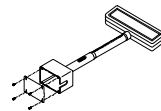

3. Connect the 2.5φ/5.5φ DC plug of the AC adapter to the 2.5φ/5.5φ DC jack inside the base cabinet.

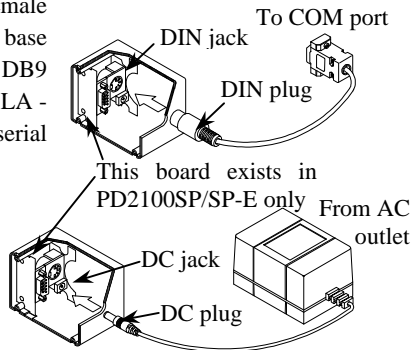

4. Put the metal plate back and fix the screws.

5. Mount the pole display stand plate to the metal plate of base cabinet with screws and mount the pole display stand plate to your Posiflex cash drawer (CR310X or CR320X) or on the cashier's dash.

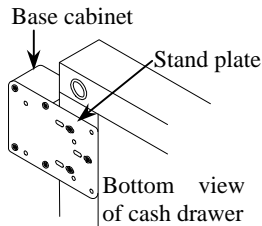

6. Plug the adapter into power outlet. Check the specification of power adapter on its nameplate.

7. A firmware version as power on - sign will appear for a while. Then a blinking block-shaped cursor will appear at the left-most digit of the top row for Futaba or Noritake emulation mode and no cursor will appear for other emulation modes. The installation is now completed.

B. PD2100SP/SP-E Installation (Serial Pass Through)

1. Take off the metal plate on the Pole display base cabinet by loosening the screws. Same way as PD2100S/S-E.
2. Connect the DIN 5 pin plug of the cable CCBLA - 125A to the female DIN 5 pin connector inside the base cabinet and connect the DB9 connector of the cable CCBLA - 125A to the computer's serial port of COM1 or COM2. Same way as PD2100S/S-E.
3. Connect the 2.5 ϕ /5.5 ϕ plug of the AC adapter to the 2.5 ϕ /5.5 ϕ jack inside of the base cabinet. Same way as PD2100S/S-E.

4. Connect the DB9 female connector of the serial pass through cable to the DB9 male connector inside the base cabinet and connect the other DB9 connector of the serial pass through cable to the next RS232 peripheral device.

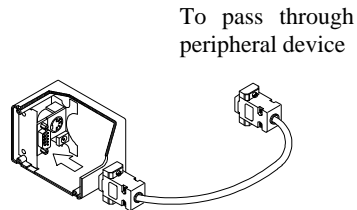

5. Put the metal plate back and fix the screws.
6. Mount the pole display stand plate to the metal plate of base cabinet with screws and mount the pole display stand plate to your Posiflex cash drawer (CR310X or CR320X) or on the cashier's dash. Same way as PD2100S/S-E.
7. Plug the adapter into power outlet. Check the specification of power adapter on its nameplate.
8. A firmware version as power on - sign will appear for a while. Then a blinking block-shaped cursor will appear at the left-most digit of the top row for Futaba or Noritake emulation mode and no cursor will appear for other emulation modes. The installation is now completed.

C. PD2100PP Installation (Parallel Pass Through)

1. Connect the DB25 male connector of the normal printer cable from the cascaded printer interface device to the DB25 female connector of the cable CCBLA - 174 that comes out of the base of PD2100PP.
2. Then connect the DB25 female connector of the accessory cable CCBLA - 089 - 1 to the DB25 male connector of the cable CCBLA - 174 from base of PD2100PP. Connect the DB25 male connector of the accessory cable CCBLA - 089 - 1 to the parallel port of the host computer.
3. Connect the 2.5 ϕ /5.5 ϕ plug of the AC adapter to the 2.5 ϕ /5.5 ϕ jack of the cable CCBLA - 174.

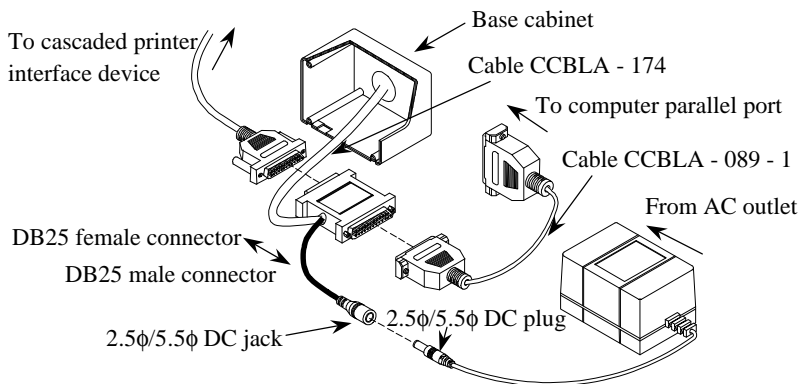

4. Mount the pole display stand plate to the metal plate of base cabinet with screws and mount the pole display stand plate to your Posiflex cash drawer (CR310X or CR320X) or on the cashier's dash.
5. Plug the adapter into power outlet. Check the power adapter specification on its nameplate.
6. A firmware version as power on - sign will appear for a while. Then a blinking block-shaped cursor will appear at the left-most digit of the top row for Futaba or Noritake emulation mode and no cursor will appear for other emulation modes. The installation is now completed.

D. PD2101/PD2201 Installation for PST Series

Follow the instructions on manuals for each PST series for mechanical installation of PD2101/PD2201 to each PST systems. Connect the 10 pin plug of the PD2101/PD2201 to the 10 pin VFD jack inside the PST system back door.

E. PD2200/PD2200A Installation

1. Establish Power Supply Connector from PC

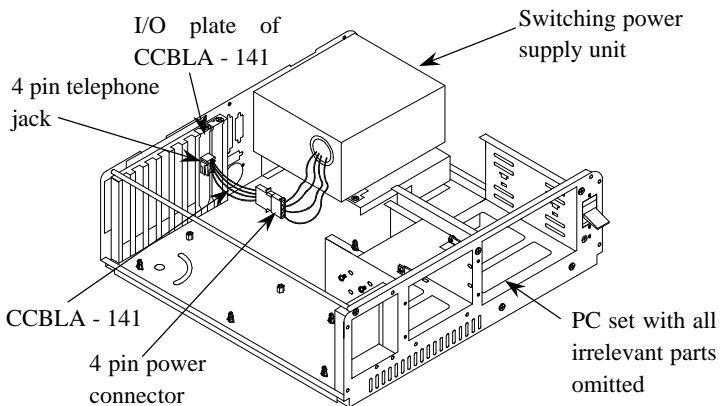

The cable CCBLA - 141 in the accessory is a cable with the 4 pin connector for PC power supply connection and a PC I/O plate mounted with a 4 pin telephone jack. This cable is particularly suitable for obtaining DC power for the peripherals from the hosting PC. The drawing above indicates an example of how to install this CCBLA - 141 into a PC. However, it is absolutely important to **turn all the power off** before removing any case or connecting any cable.

Followings are the instructions for installing this cable:

- a. Make sure the PC to supply power is turned off.
- b. Open the case of PC according to its relevant manual.
- c. Select one I/O plate position on rear window of PC to install the I/O plate of CCBLA - 141.
- d. Select one set of large 4 pin connector from the switching power supply unit of PC and connect the male 4 pin connector of CCBLA -

141 to the connector from power supply. Connect the female 4 pin connector of CCBLA - 141 to the I/O device of PC such as a HDD if necessary.

- e. Assemble the case of PC back and get ready for use.

2. Connect the Display for Both Signals and Power

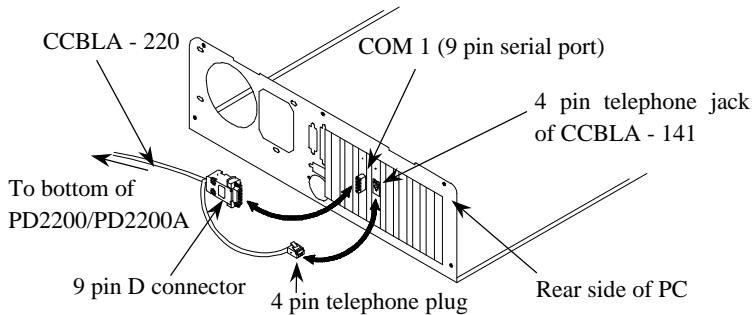

The cable CCBLA - 220 is used to connect the customer display PD2200/PD2200A to the host PC and to get power supply for PD2200/PD2200A at the same time. Be sure that the power to the PC is turned off before connecting for CCBLA - 220.

Followings are the instructions for installing this cable:

- a. Turn the switch at the base of PD2200/PD2200A off and connect the 25 pin male connector of CCBLA - 220 to the 25 pin female connector at the bottom of the base of PD2200/PD2200A. Let the cable come out of the bottom of PD2200/PD2200A through the opening at the back of base so that the PD2200/PD2200A can stand securely.
- b. Connect the 9 pin female connector of CCBLA-220 to the 9 pin male connector for serial port such as COM 1 of the host PC.
- c. Connect the 4 pin telephone plug of CCBLA - 220 to the 4 pin telephone jack on the I/O plate of CCBLA - 141 which has been mounted as described in the previous paragraph.

- d. Now the user may turn on the PC and the PD2200/PD2200A for application unless the user wants to use PD2200/PD2200A for pass through purpose.

3. Connect for Pass Through Operation

In PD2200/PD2200A the jumper setting are set internally to pass through mode, while the PD2200/PD2200A is delivered with a COM port terminator on the 9 pin male connector in the bottom of PD2200/PD2200A. In this way, the PD2200/PD2200A serves the non-pass-through operation well. For pass through operation, the user has to merely remove this COM port terminator and connect the pass through connected device in stead.

4. Connect the Optional Power Adaptor

The optional power adaptor used for PD2200/PD2200A should be able to supply 7.5V AC power through a 2.5 ϕ /5.5 ϕ plug if the user does not want to use the power from PC through CCBLA - 141. The user shall connect the plug to the jack beside the 9 pin D connector at the bottom of PD2200/PD2200A. You can order this power adaptor from your dealer. The part numbers are CADPTR7.5V1.5A120 or CADPTR7.5V1.5A230 for PD2200 and CADPTR12V1.5A120 or CADPTR12V1.5A230 for PD2200A.

V. MECHANICAL FEATURES

A. Dimension Drawings

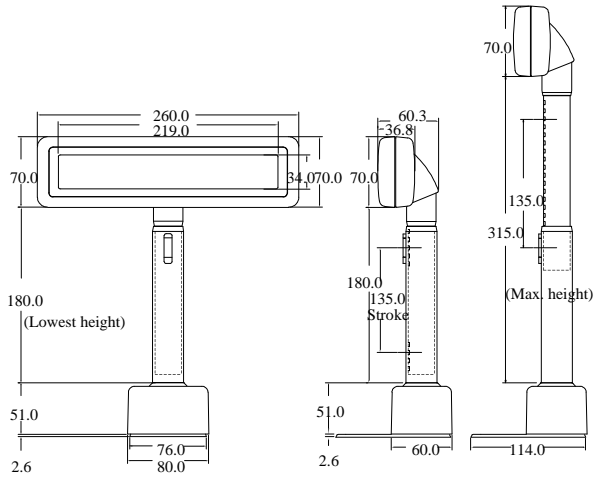

PD2100 Series

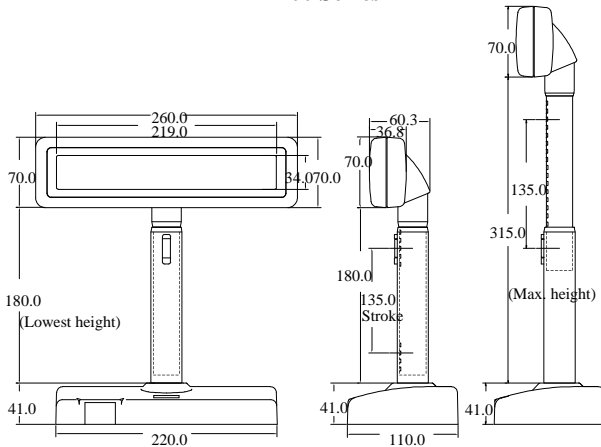

PD2200 Series

B. Display Frame Common Features

In addition to the above drawings given, both the PD2100/PD2200 series are delicately designed to have in common the following user-friendly mechanical features for most up-to-date store management systems.

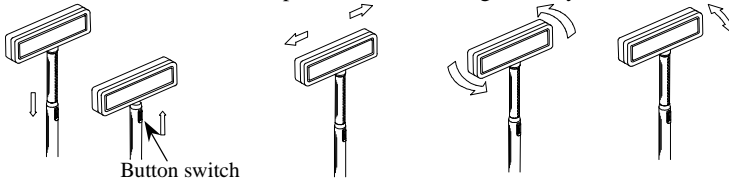

The display panel of PD2100/PD2200 series can be moved or rotated/tilted both vertically and horizontally

The overall pole height can be adjusted freely by pulling the button switch and match it to one of the concave cavities on inner pole at a proper height except PD2100PP. Overall height of PD2100 series except PD2100PP is adjustable from 309mm to 444mm and overall height of PD2200 series is adjustable from 291mm to 426mm. Overall height of PD2100PP is 309mm only.

The display frame can be slid left-and-right-wise for a total sliding distance of 100mm. It can also be rotated horizontally for almost 360 degree, however, the rotation is limited to within 360 degree to avoid the internal cable to be broken. It can further be tilted to offer 2 different viewing angles ---14.5°, 30° from the vertical position.

C. Cushion Against Shock Coming from Any Direction for PD2100S/S-E/SP/SP-E/PP

Another special delicate design at bottom of PD2100S/SP/PP is a cushion mechanism to survive an inevitable crash or damage on pole display from certain absent - minded customers, playing children and so on. It will absorb any external stress or bump to avoid any damage of the device.

D. Stand - Plate Accessory for PD2100S/S-E/SP/SP-E/PP

The stand - plate accessory is designed to fix pole display device either on the desk with (or without) screws or at the bottom of CR3100/3200 series cash drawers.

VI. FUNCTIONAL TEST

When anything goes wrong in the application of a customer display, there are a number of potential causes other than the customer display itself like the cabling, operation system and the application software. The following test sequence under DOS environment can be used to verify if the customer display is working properly. This test procedure assumes the customer display (if not PD2100PP) is plugged into COM1 port of the host computer and the PD2100PP is plugged into LPT1 port of the host computer. If other port like COM2 or LPT2 is used, change “COM1” to “COM2” or “LPT1” to “LPT2” in the following procedure. With the host computer turned on and running DOS:

A. For PD2100S/S-E/SP/SP-E and PD2200/PD2200A

1. Type “MODE COM1 96,N,8,1”. Hit the ENTER key.
2. Type “TYPE CON > COM1”. Hit the ENTER key.
3. Type “ABCDEFGHJKLMNOPQRS”. Hit the ENTER key.
If the following characters show up on the display, the customer display is working normally:
ABCDEFGHJKLMNOPQRS
4. Hit Ctrl-C (press Ctrl and C keys together) to return the computer back to the normal display mode.

B. For PD2100PP

1. Type “TYPE CON > LPT1”. Hit the ENTER key.
2. Type “ABCDEFGHJKLMNOPQRS”. Hit the ENTER key.
If the following characters show up on the display, your pole display is working normally:
ABCDEFGHJKLMNOPQRS
3. Hit Ctrl-C (press Ctrl and C keys together) to return the computer back to the normal display mode.

VII. INTERFACE

The PD2100S/S-E/SP/SP-E and PD2200/PD2200A are factory configured for serial RS232C interface with the following protocol:

- 9600 baud rate
- 8 Data bits
- 1 Stop bit
- No parity
- Using CTS signal for hardware handshaking

The PD2100PP utilizes a parallel interface in SPP mode.

A. PD2100S/S-E/SP/SP-E

DIN 5 pin

Pin out from Host Computer

Pin 1 - CTS

Pin 2 - RTS

Pin 3 - Not used

Pin 4 - TXD

Pin 5 - GND

Serial Pass-through

DB9M to Next Serial Device

Pin 1 - Tied to Pin 4 & Pin 6

Pin 2 - Not used

Pin 3 - TXD

Pin 4 - Tied to Pin 6 & Pin 1

Pin 5 - GND

Pin 6 - Tied to Pin 1 & Pin 4

Pin 7 - RTS

Pin 8 - CTS

Pin 9 - Not used

B. PD2100PP

Connector Pin Assignment

Input DB25M and Output DB25F Connector – to Host Computer

Pin 1 - STROBE	Pin 13 - SLCT
Pin 2 - DATA 0	Pin 14 - #AUTO LF
Pin 3 - DATA 1	Pin 15 - #ERROR
Pin 4 - DATA 2	Pin 16 - #INIT
Pin 5 - DATA 3	Pin 17 - GND
Pin 6 - DATA 4	Pin 18 - GND
Pin 7 - DATA 5	Pin 19 - GND
Pin 8 - DATA 6	Pin 20 - GND
Pin 9 - DATA 7	Pin 21 - GND
Pin 10 - #ACK	Pin 22 - GND
Pin 11 - BUSY	Pin 23 - GND
Pin 12 - PE	Pin 24 - GND
	Pin 25 - GND

C. PD2200/PD2200A

Serial Input (DCE)

DB25F from Computer

Pin 2 - RX
Pin 3 - TX
Pin 4 - RTS
Pin 5 - CTS
Pin 6 - DSR
Pin 7 - GND
Pin 8 - DCD
Pin 12 - +5V
Pin 13 - +5V
Pin 14 - GND
Pin 15 - GND
Pin 20 - DTR
Pin 22 - RI

Serial Pass-through (DTE)

DB9M to Pass-thru Device

Pin 1 - DCD
Pin 2 - RX
Pin 3 - TX
Pin 4 - DTR
Pin 5 - GND
Pin 6 - DSR
Pin 7 - RTS
Pin 8 - CTS
Pin 9 - RI

VIII. COMMAND EMULATION

A. General Concept

This VFD customer display provides totally 5 emulation modes for software programming in controlling the display. The emulation mode is defined by adjusting the DIP SW on the back according to the following table.

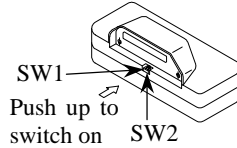

Emulation Mode	Futaba	Noritake	Aedex	Epson
SW 1	on	off	on	off
SW 2	on	on	off	off

These DIP switches may require some proper tool or special effort to change position. The switch positions must be changed only when power turned off to ensure appropriate operation. However for PD2200A and PD2201 the standard command emulation modes are:

Emulation Mode	UTC(/Futaba)	Noritake	Aedex(/ADM)	Epson
SW 1	on	off	on	off
SW 2	on	on	off	off

The parenthesized Futaba and ADM modes can be accessible when the internal jumper JP11 is opened. The followings are some brief introduction of the emulation modes as they are compared to each other:

Mode	Futaba	Noritake	Aedex	ADM	Epson
Cursor	Blinking Block	Blinking Block	N.A.	N.A.	Non-displayable
Default mode	V. scroll up	Overwrite	N.A.	N.A.	Overwrite
User defined font	N.A.	2 characters	N.A.	N.A.	2 characters
Brightness control	YES	YES	NO	NO	YES
Pass through function	YES	YES	YES	NO	YES
Leading code change	YES	YES	YES	NO	NO
Code page select	YES	YES	NO	NO	YES
Timer clock	NO	NO	NO	NO	YES

To display the Euro-dollar sign on the Euro code page supported models, please select code page 13(Hex) and display code D5(Hex).

In the following sections, a summary of commands available for each emulation mode is presented to serve as a brief introduction. Should there be any need, the user may visit the web site <http://www.posiflex.com.tw> for more details.

B. Futaba Emulation Mode

This emulation mode comes into effect when both DIP switches are pushed up (turned on).

Listed below are commands available in this mode grouped by their functions, note that all the command codes given are expressed in Hexadecimal format. For detail description of the listed commands, please visit our web site <http://www.posiflex.com.tw> and look for “PD2X00 Command Emulation”.

Command Name	Hex Codes	Command Name	Hex Codes
Reset	1F	Digit select	10 pp
Brightness control	04 bb	Cursor on	13
Change code page	1E pp	Cursor off	14
International character set	1C 0i	Back space	08
Moving sign	05 0D	Horizontal tab	11 09
Change leading code	06 x1 x2	Vertical scroll up	12 09
Set pass through flag	01	Cursor up/down	11 0A
Clear pass through flag	x1 x2 02	Line feed	12 0A
		Carriage return	0D

C. Noritake Emulation Mode (Default Setting)

This emulation mode comes into effect when the left DIP switch is pushed down (turned off) and the right one is pushed up (turned on).

Listed below are commands available in this mode grouped by their functions, note that all the command codes given are expressed in Hexadecimal format. For detail description of the listed commands, please visit our web site <http://www.posiflex.com.tw> and look for “PD2X00 Command Emulation”.

Command Name	Hex Codes	Command Name	Hex Codes
Reset	1B 49	Cursor blinking Rate	1B 54 nn
Clear	0E	Cursor on	15
Brightness control	1B 4C bb	Cursor off	16
Change code page	1E pp	Back space	08
International character set	1C 0i	Horizontal tab	11 09
Moving sign	05 0D	Vertical scroll up	12 09
Change leading code	06 x1 x2	Cursor up/down	11 0A
Set pass through flag	01	Line feed	12 0A
Clear pass through flag	x1 x2 02	Form feed	0C
Digit select	1B 48 pp	Carriage return	0D
User defined graphics/fonts	1B 43 ad x1 ~ x5		

D. Aedex Emulation Mode

This emulation mode comes into effect when the left DIP switch is pushed up (turned on) and the right one is pushed down (turned off).

The available function codes and some of the limitations in this emulation mode are listed in the table below. For detail description of the listed commands, please visit our web site <http://www.posiflex.com.tw> and look for “PD2X00 Command Emulation”. Note that the complete command form must be:

Attention code + Function code + Data + Carriage return

Function Code	Command Name	Function Area	Data Length
1	Display top	Top row	Max. 20 characters
2	Display bottom	Bottom row	Max. 20 characters
4	On going scroll	Top row	Max. 60 characters
6	One time scroll	Top row	Max. 40 characters
7	Stop trapping	N.A.	No characters

8	Change attention code	N.A.	2 characters
9	Display whole area	Both rows	Max. 40 characters

E. ADM Emulation Mode

This emulation mode comes into effect when the left DIP switch is pushed up (turned on) and the right one is pushed down (turned off).

The available command codes and some of the limitations are listed in the following table and note that all the command codes given are expressed in Hexadecimal format. For detail description of the listed commands, please visit our web site <http://www.posiflex.com.tw> and look for “PD2X00 Command Emulation”. Note that the complete command form must be:

Control code [+ Data / Line #] [+ Carriage return]

Control Code	Command Name	Function Area
0C	Clear Display	Line 1 +Line 2
0D	Carriage Return	End of Command
0E	Write Line 1	Line 1
0F	Write Line 2	Line 2
10	Write Decimal Point	Line 1
11	Blink Line	Line 1 or Line 2
12	Clear Blink	Line 1 or Line 2
1E	Write Field 1	Left 8 characters of Line 2
1F	Write Field 2	Right 8 characters of Line 2

F. Epson Emulation Mode

This emulation mode comes into effect when both DIP switch are pushed down (turned off).

Listed below are commands available in this mode grouped by their functions, note that all the command codes given are expressed in Hexadecimal format. For detail description of the listed commands, please visit our web site <http://www.posiflex.com.tw> and look for “PD2X00 Command Emulation”.

Command Name	Command & Hex Codes	Command Name	Command & Hex Codes
Move cursor left	BS 08	Mark semicolon	US ; 1F 3B
Move cursor right	HT 09	Clear mark	US < 1F 3C
Move cursor down	LF 0A	Set/cancel display screen blinking	US E 1F 45 n
Move cursor home position	HOM 0B	Set and display counter (time)	US T 1F 54 h m
Clear display screen	CLR 0C	Brightness adjustment	US X 1F 58 0n
Move cursor to left-most position	CR 0D	Set/cancel user-defined characters	ESC % 1B 25 0n
Clear cursor line	CAN 18	Define user-defined characters	ESC & 1B 26 addr x1 x2 x3 x4 x5
Specify overwrite mode	US MD1 1F 01	Delete user-defined characters	ESC ? 1B 3F 0n
Specify vertical scroll mode	US MD2 1F 02	Show firmware version	US @ 1F 40
Specify horizontal scroll mode	US MD3 1F 03	Select peripheral device	ESC = 1B 3D 0n
Move cursor up	US LF 1F 0A	Select character code page table	ESC t 1B 74 mn
Move cursor to right-most position	US CR 1F 0D	Move cursor to bottom position	US B 1F 42
Move cursor to specified position	US \$ 1F 24 n m	Initialize display	ESC @ 1B 40
Mark comma	US , 1F 2C	International character set	ESC R 1B 52 0i
Mark period	US . 1F 2E	Display counter (time)	US U 1F 55

IX. SPECIFICATIONS

A. Optical

Number of digits	20 digits/row, 2 rows
Dot matrix	5 X 7 dots
Digit height	11.25 mm
Digit width	7.2 mm
Color	Green, $\lambda = 505$ nm

B. Mechanical

Weight	1.5 lbs
Height	309 ~444 mm (For PD2100S/S-E/SP/SP-E) 309 mm (For PD2100PP) 291 ~ 426 mm (For PD2200/PD2200A)
Width	260 mm
Depth	60 mm (For PD2100S/S-E/SP/SP-E/PP) 110 mm (For PD2200/PD2200A)

C. Electrical

Power (Applied to adapter)	
Input:	120VAC, 60 Hz or 220VAC, 50 Hz
Output:	7.5VAC heavy duty (For PD2100 S/S-E/SP/SP-E/PP and PD2200) 12VAC heavy duty (For PD2200A)

D. Environmental

Operating temperature	0° to + 40°C
Storage temperature	-20° to + 70°C
Relative humidity	90%, non-condensing
Vibration	4 G
Shock	40 G



WARNING: If the user opens the pole display housing to make any change, all the product warranty will be voided.